



Repair and Service Document

FV-G-002
Rev. 02/21

Please fill in electronically!

Last Name:	Phone:
First Name:	E- Mail:
Street:	VAT ID Number:
City, ZIP:	Different Delivery Address:
Country:	

Include any additional accessories that might be needed for the fault analysis (charger, SD card etc.)
Please remove any third party equipment/accessories before packaging your product. We assume no liability for damage.

ATTENTION! DO NOT SEND IN BATTERIES!

Product:	Yes	No
Serial Number:		
Warranty Documents:		

Detailed fault description or additional information:

Product:	Yes	No
Serial Number:		
Warranty Documents:		

Detailed fault description or additional information:

Accessories:

IMPORTANT! If the fault concerns image quality (f.e. dead pixels, blurriness, reflexes etc.) please include a sample in uncompressed DNG format on SD card or USB flash drive.

Automatically release the estimate if the amount does not exceed



Repair and Service Document

FV-G-002
Rev. 02/21

Please insure the following:

Battery function test conducted

SD Card formatted

Latest Firmware installed

Reset to factory settings has been performed: Yes

Not applicable

Signs of use: Slight Normal Heavy

Additional Information:

Please mark location of damage that is not considered a sign of use (dents, deeper scratches etc.) To be used for all products incl. S/SL.

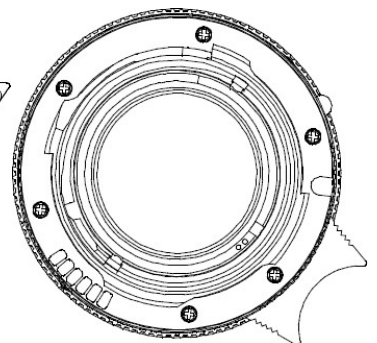
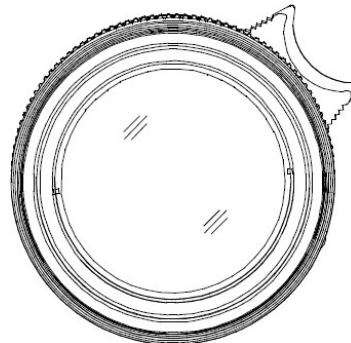
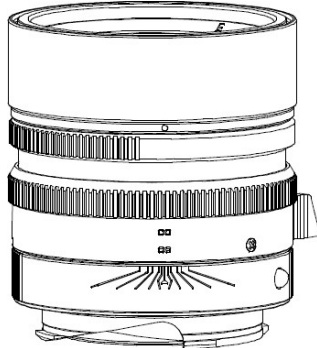
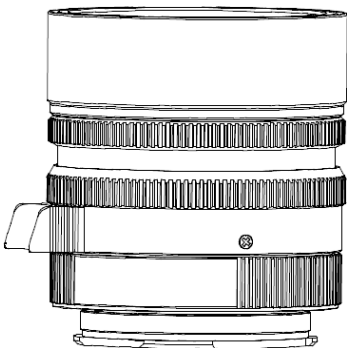
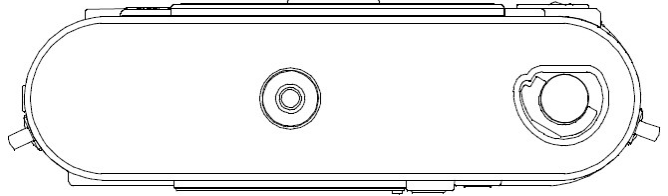
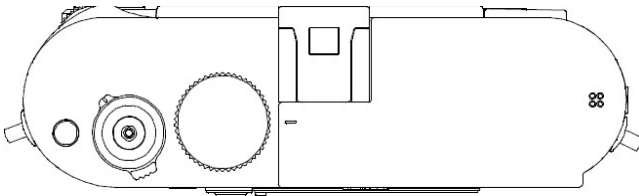
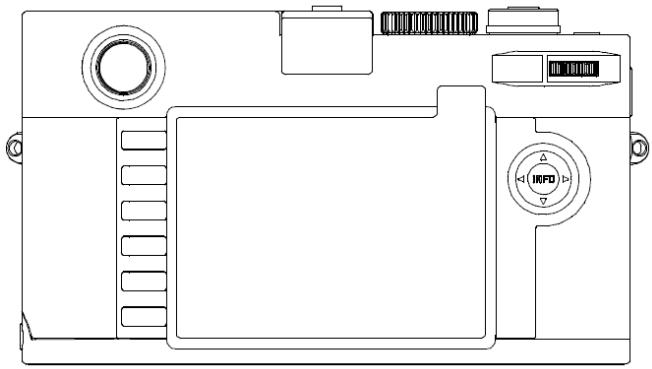
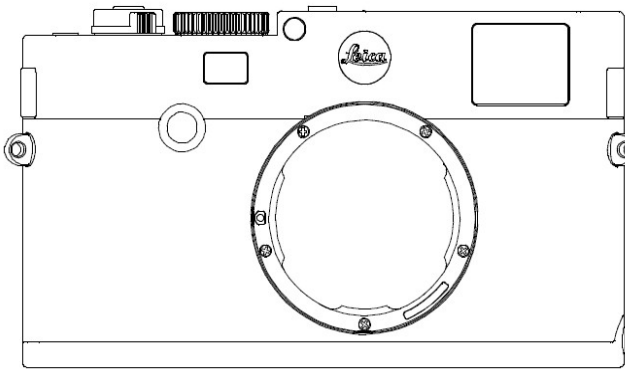

I hereby confirm the condition of my product as described in this document (to be signed by customer)

City, Date:

Signature: